



Wright Manufacturing, Inc.

Work Inst. Name: **61 Inch Aero Core Mulch Kit** **Instructions**

Inst. Number: **SVC-SWI-0008**

Revision: 01

Issue Date: N/A

Author: Chris Sturtz

Date: 2/26/15

Reviewer: Chris Sturtz

Date: 2/26/15

Approver: Chris Sturtz

Date: 2/26/15

95450011 MULCH KIT Parts List

P/N	Description	Qty.
11990013	BOLT, FLANGE 5/16-18 X 1 Z5	3
11990016	BOLT, CARRIAGE 3/8 X 1 Z5	2
12990007	NUT, LOCK FLANGE 5/16-18 Z	3
12990031	NUT, TOP LOCK 3/8-16	2
93450046	MULCH DISCHARGE WELDMENT, 61"	1
93450048	MULCH TRIM WELDMENT, 61"	1
93450047	MULCH CENTER WELDMENT, 61"	1
93460129	MULCH BLOCK OFF PLATE	1

- 1) Raise and secure machine.
- 2) Make sure to use all safety precautions.
- 3) Clean bottom of deck thoroughly.
- 4) Remove factory installed Flow Baffle and save the hardware, it will be reused to install the mulch kit.
- 5) Install the Trim weldment and Discharge weldment first. (Fig.1) (Do not fully tighten hardware at this time)
- 6) Install the Center weldment. (Fig.2)
- 7) Install Block off plate and tighten all hardware. (Fig.3)
- 8) Rotate blades by hand to make sure they do not hit mulch kit baffle – adjust baffle if necessary.

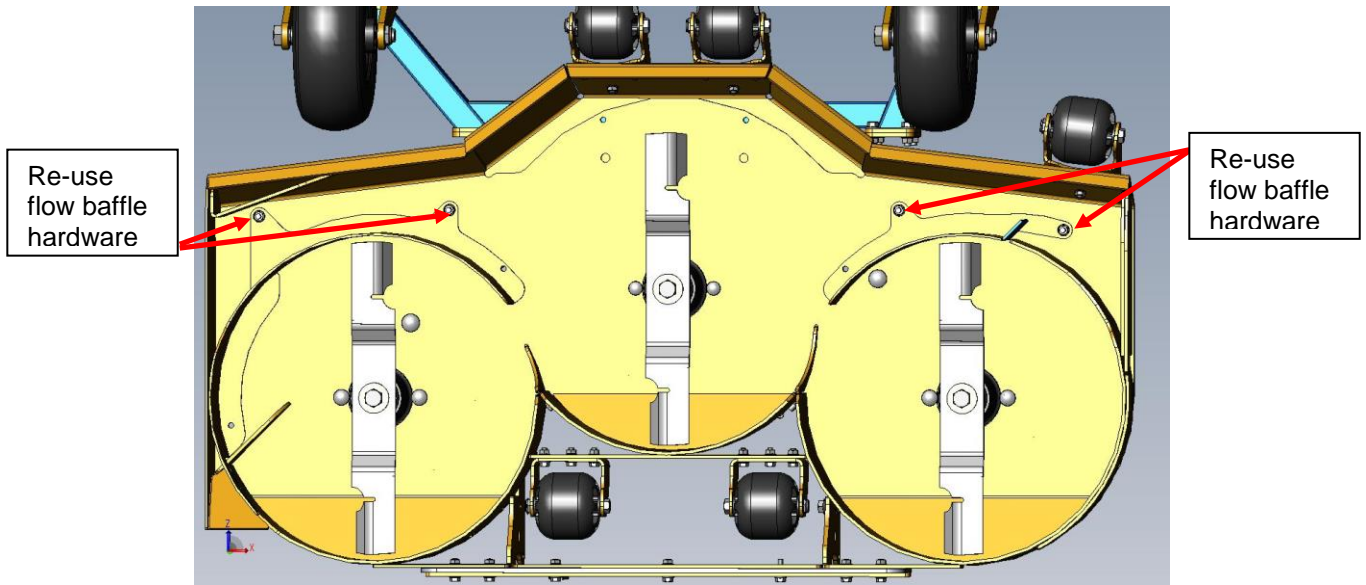

Figure 1

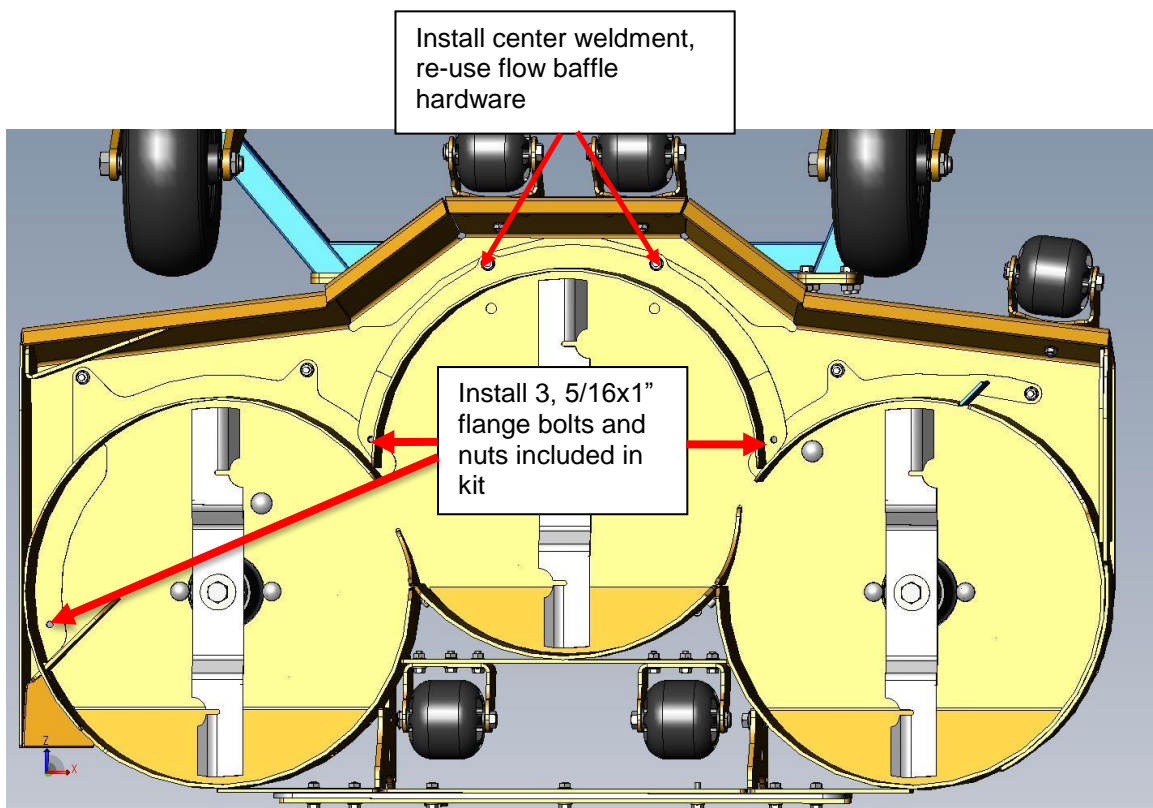

Figure 2

Install 2, 3/8x1" carriage bolts and toplock nuts included in kit

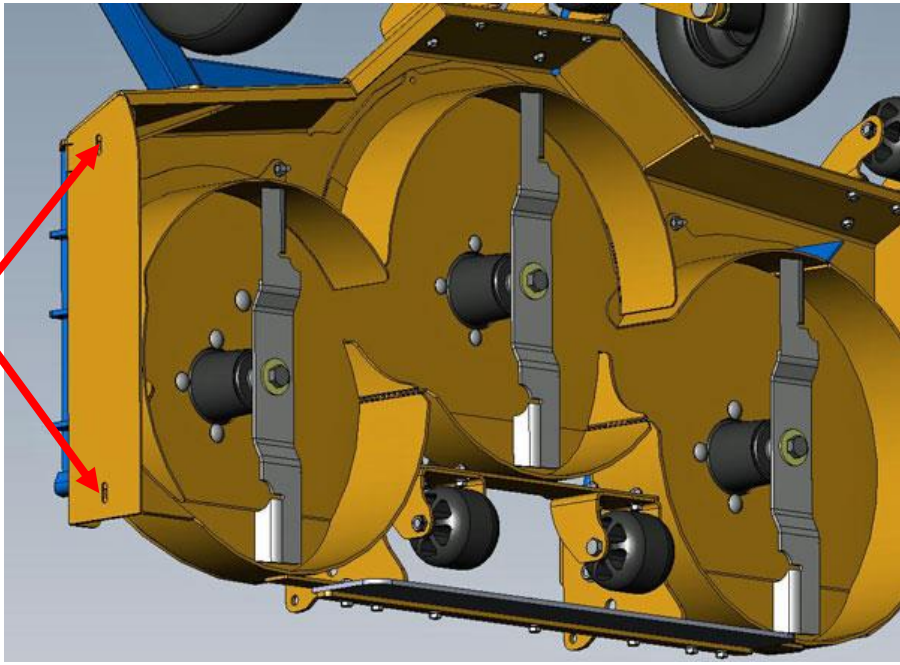

Figure 3

Revision Table

Name	Date	Reason for Changes	Version
Ed Wright	N/A	Initial Release	00
Chris Sturtz	2/26/15	Format Update	01